

molex® 1000Base-T RJ-45 Gigabit Ethernet SFP Copper Transceiver
74741

The 1000Base-T RJ-45 Gigabit Ethernet SFP copper transceiver module is a high-performance integrated duplex data link for bi-directional communication over Category 5 copper cable. The hot-pluggable feature allows changing to and from another SFP-compatible module without having to remove system power. Serial ID is included.

Molex's RJ-45 SFP module provides multiple customer-friendly features. A link monitor detects loss of signals. The Serial ID allows individual identification of each SFP transceiver. An auto-power saving mode conserves energy. The centered RJ-45 modular jack conforms to a 1U rack for ease of installation, and its design allows side-by-side stacking for increased density.

Features and Benefits

- 1000Base-T compliant module meets IEEE802.3z, ab, u specifications and is SFP MSA compliant
- Less than 1 Watt power requirement provides low heat output
- Zinc backshells provide improved EMI performance
- Auto-negotiation feature allows networking equipment to automatically determine and adjust to the required settings
- Automatic MDI crossover eliminates the need for crossover cables or cross-wired (MDIX) ports
- Bail latch provides ease of extraction

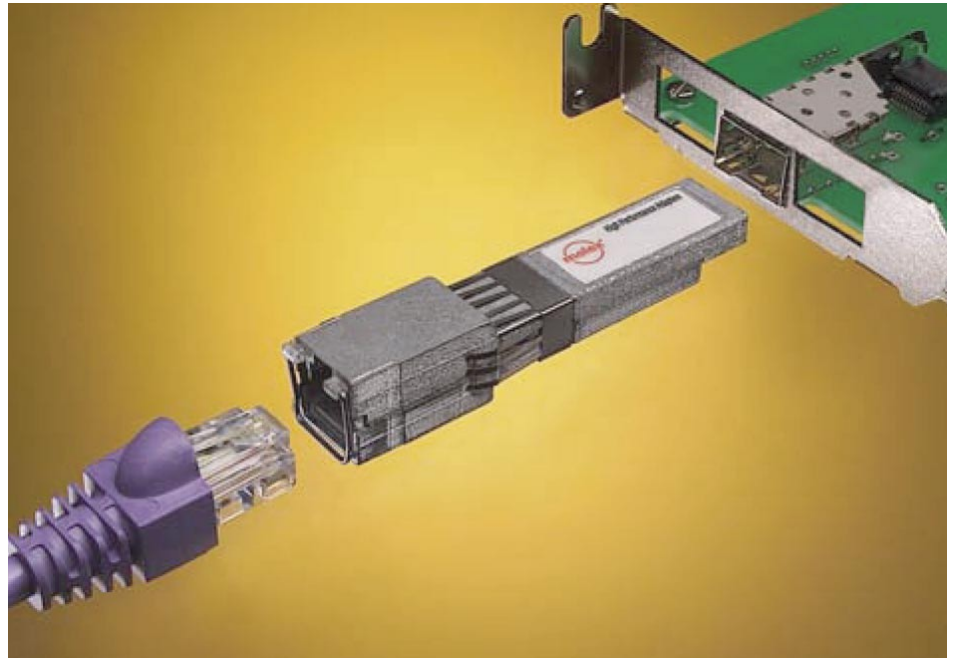

Specifications

Reference Information

Packaging: Box
Mates with: SFP Cage 73927
SFP Connector 74441

Electrical

Voltage: 3.3V
Current: 285mA
Power: 1 W max.

Physical

Diecast Backshell: Zinc
PCB Thickness: .099mm (.039")
Operating Temperature: 0 to +70°C

Applications

- Networking
- Switches
- Routers

OVERVIEW

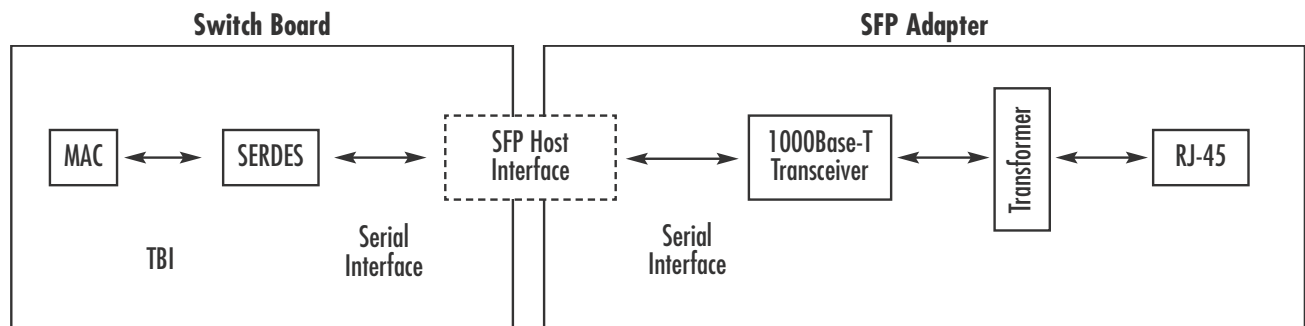

RJ-45 SFP 1000Base-T Application



1000Base-T RJ-45 Gigabit Ethernet SFP Copper Transceiver

74741

SFP Mode

When the internal Gigabit Ethernet transceiver (PHY) is configured to SFP mode, the PHY interfaces directly with the host serial/deserial (SerDes) interface. The host interface transmits and receives serial data differentially at 1.25 Gbps. The copper interface is full featured and advertises full/half duplex, and 1000Base-T wire speed.

Auto-Negotiation

The Category 5 copper link negotiates according to the IEEE 802.3 Clause 28, and the SerDes interface negotiates using Clause 37. The two interfaces advertise 1000Base-T full-duplex, and master/slave relationships. The master establishes the time control from its local clock source. The slave, however, recovers the clock from the received data stream. The SFP application is limited to 1000Base-T wire speed only. Auto-negotiation on the SerDes link is always restarted when a change is detected on copper link.

The SFP 1000Base-T features a Serial Interface (SerDes) Auto-Negotiation Bypass mode. This mode disables auto-negotiation after 200ms of unsuccessful attempts with the host, without the need for manually configuring the auto-negotiation parameters. The Molex SFP 1000Base-T module will transmit data with auto-negotiation disabled.

Automatic MDI Crossover

The SFP 1000Base-T transceiver performs a MDI crossover during auto-negotiation, eliminating the need for crossover cables or cross-wired (MDIX) ports.

Automatic Polarity Correction

Should the polarity of receive signals inadvertently become reversed, the SFP 1000Base-T will automatically correct them based on the sequence of idle signals received.

Auto Power Savings Mode

When the copper link is lost, the SFP automatically enters a low power mode, reducing the chip power requirements. Full power mode resumes once the copper link is re-established.

Serial ID

Serial identification is implemented on the SFP 1000Base-T transceiver. The serial protocol uses a two-wire I2C interface.

Software Reconfigurable

The SFP 1000Base-T is hardware configured on power-up. The configuration can be changed by a register write via a two-wire bus (I2C) at any time. For further details, refer to the Molex SFP 1000Base-T software configuration application note.

AUTO-NEGOTIATION SUMMARY

Auto-Negotiation Features Implemented

General:

- SerDes auto-negotiation is restarted when a change is detected on the copper link
- Auto power savings mode when copper link is lost

Copper RJ-45 Interface:

- Auto-negotiation
- Copper SFP speed 1000Base-T
- Full duplex
- Automatic MDI crossover
- Master/slave relationships
- Pause flow control
- Software reconfigurable

Host SerDes Interface:

- Differential SerDes interface at 1.25 Gpbs
- Master/slave relationships
- SerDes recovers the clock from the received data stream
- Pause flow control

Americas Headquarters

Lisle, Illinois 60532 U.S.A.
1-800-78MOLEX
amerinfo@molex.com

Far East North Headquarters

Yamato, Kanagawa, Japan
81-462-65-2324
feninfo@molex.com

Far East South Headquarters

Jurong, Singapore
65-6-268-6868
fesinfo@molex.com

European Headquarters

Munich, Germany
49-89-413092-0
eurinfo@molex.com

Corporate Headquarters

2222 Wellington Ct.
Lisle, IL 60532 U.S.A.
630-969-4550
Fax:630-969-1352

Visit our Web site at <http://www.molex.com>